

## Air Dispersion Modeling for the Assessment of ULCOS Technologies

Marco Vannucci<sup>1</sup>, Valentina Colla<sup>1</sup> and Neil Haines<sup>2</sup>

<sup>1</sup>Scuola Superiore S.Anna, Pisa, Italy & <sup>2</sup>CORUS, UK

[mvannucci@sssup.it](mailto:mvannucci@sssup.it)

Among the local impacts which are considered within the Sub Program 9.3 of the Ulcos project for the assessment of technologies sustainability, air quality is a key issue for the evaluation of the environmental impact of a steel plant in its surrounding area. In this paper a method based on the use of air dispersion modelling is proposed for the assessment of the Ulcos technologies on the basis of the concentration in the atmosphere of the main pollutants (NO<sub>x</sub>, SO<sub>2</sub>, TSP, PM10, PM25, CO, Pb, PCDD) produced by the plant. For performing this task the AERMOD model, a widely used model belonging to class of Gaussian models, was used. For exploiting AERMOD it was necessary to characterize the case base plant specifying the positions and dimensions of its main parts and its stacks as well as the characteristics of their emissions. Furthermore it was necessary to collect information on the meteorological conditions and the terrain of the considered zone. The results, measured in terms of average concentration of the pollutants at ground level, show that such concentrations are below the limits established by current legislation. In the future these results will be used for comparisons of the case base with new technologies.

### Introduction

The sustainability of Ulcos technologies must be evaluated taking into account various aspects among which local impact is a key issue as it represents the influence of the presence of a steel plant in the surrounding area according to several aspects including the social and environmental ones.

Air quality is an important aspect of local impacts which aims to assess the influence of the steel plant on the air pollution in the nearness of the plant. In this work the air quality in terms of the concentration of the main pollutants produced by a standard steel plant was investigated by means of air dispersion modelling techniques which are normally exploited for this purpose. For this modelling task a base case plant has been defined, represented by an average in-land European plant. Information related to such plant concerning its emission, parts positions, weather conditions and terrain features have been retrieved and the obtained results obtained from the simulation have been used for the evaluation of the base case (BF route) and as a touchstone for some considerations on the new Ulcos routes.

The paper is organized as follows: in part 1 the general modelling work carried out is described and an introduction to the utilized modelling tools is proposed; in part 2 the details of the base case utilized in this work are reported and the results of the air dispersion modelling simulation are shown in part 3; finally some conclusions and the future work perspectives are drawn.

### Part 1. Air dispersion modelling

The dispersion of pollutants in the air is influenced by several factors related both to the nature of emitted pollutants and their physical properties both to the plant characteristics and geographical properties of the zone for which the model is applied. On the basis of these informations an air dispersion model simulates the behaviour of the observed gas in the atmosphere and calculates their concentration in the atmosphere. For the purpose of the work the average ground level concentration of the following set of pollutants established within the SP9.3 working group was calculated:

- NO<sub>x</sub>
- SO<sub>2</sub>
- TSP
- PM<sub>10</sub>
- PM<sub>2.5</sub>
- CO
- Pb
- PCDD

This set of pollutants corresponds to the main emissions produced by a standard plant and mainly affect air quality.

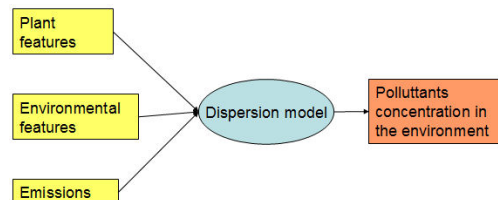

**Figure 1.** A schematic representation of the input-output of the adopted air dispersion model

Air dispersion models simulate by means of several mathematical equations and algorithms how the pollutants disperse in the atmosphere. These equations are based on: meteorological conditions (wind speed

and direction, stability class of the particular atmosphere, air temperature profile); emissions parameters such as source location and height, stack diameter and exit velocity, exit temperature and mass flow rate; terrain morphology (i.e. elevation of the zone surrounding the emitting plant); the presence, positions and dimensions of buildings or other structures which can affect the path of the emission.

Many of the modern, advanced dispersion modeling programs include a pre-processor module for the input of meteorological data, and many also include a post-processor module for graphing the output data and/or plotting the area impacted by the air pollutants on maps.

Air quality models can be classified on the basis of their approach to the problem in 4 groups.

Gaussian models are the most widely used technique for estimating the ground level concentration of non-reactive pollutants. They are based on a simple formula that describes the three-dimensional distribution of a pollutant generated by a point source.

Numerical models are used mainly for area source urban applications and involve reactive pollutants. Eulerian and Lagrangian models belong to this class and differ on the adopted reference system: in the Eulerian the reference system is fixed with respect to the earth, while the Lagrangian follows the average atmospheric motion.

Statistical methods are frequently used in those situations where there is lack of knowledge of data and context information and exploit air quality measurements to infer semi-empirical cause-effect relationships.

Physical models are used for modelling complex situations and are applied to limited regions. They involve the use of wind tunnel or other fluid modeling facilities.

Dispersion models are often used for the assessment of air quality in various frameworks and for different aims. There are numerous examples of their use for the evaluation of the impact of pollution generated by urban areas as for instance in [9] where the emissions of a whole city are considered or in [10] where the specific impact of single and possibly small sources is evaluated. On the other hand these kinds of models have also widely been used for the assessment of industrial pollution impact as for instance in [11] and [12] where several models have been tested and compared for real world applications.

Gaussian model are based on the equations proposed in [1] and improved in [2] and [3] which assume the distribution of the vertical and crosswind dispersion of the pollutants flow (called *plume*) to be Gaussian and also include the effect of ground reflection of the plume. Such Gaussian model equations are based on the calculation of the height  $H$  which is the pollutant plume's centerline height above ground level and was studied by Briggs in [4] and [5]. These concepts are illustrated in Figure 2.

AERMOD is the most known and widely used Gaussian air dispersion model. It is a steady state advanced plume model that incorporates updated treatments of the boundary layer theory, understanding of turbulence and dispersion and includes handling of terrain interactions.

AERMOD was expressly designed to be used for relatively small regions (up 100 Km). AERMOD model includes also 2 data preprocessors, one for the pre-processing of meteorological data and the other for the terrain data and a tool for the calculation of the interaction of buildings with the plume. Several characteristics make this model suitable for the simulation of the short range dispersion of pollutants generated by an industrial complex [6] [8]. It is since year 2000 the EPA's preferred model for the air dispersion simulations both for simple and complex terrains. AERMOD is able to model a wide set of different features [6] [7]: multiple types of sources (multiple points or surface); source location (urban or rural); emissions continuity; plume dispersion treatment on the basis of atmosphere stability; a variety of meteorological situations.

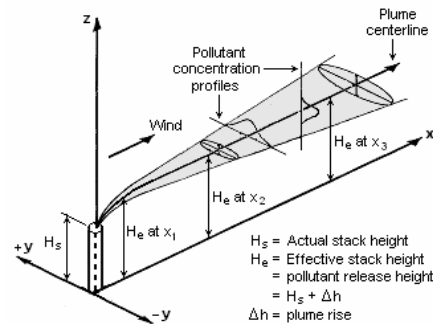

Figure 2. Schematization of the physical model on which AERMOD is based

## Part 2. The base case

For the simulation it was decided, within SP9.3, to design a specific case base reflecting a standard steel plant in order to generate results usable for future comparison with analogous results obtained by the other technologies. The case base consists in an in-land plant with a HRC production of 4MT/y located in central Europe. The considered case base is in line with the case study defined within the whole SP9 as a term of comparison for all ULCOS technologies.

All the interesting characteristics of the case base configuration have been collected to be fed to the model. In particular the disposition and the structure of plant buildings; several information concerning emissions features and meteorological and terrain info of this case were taken into account.

More in detail the position of the main parts of the steel plants have been collected as well as the stack height of the emitting sources. In particular data were collected for the following structures: coke ovens, sinter plant, blast furnace, hot mill, power plant

and BOF. The relative positions of these buildings are shown in Figure 2.

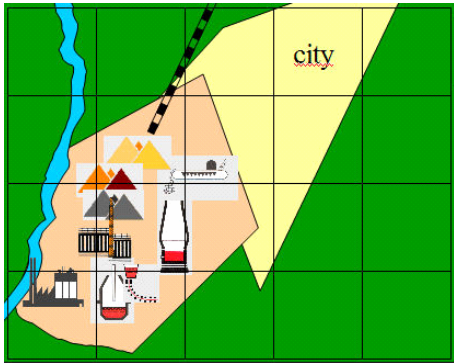

**Figure 3.** This map represents the main buildings forming the case base steel plant. In this figure the orientation of the building is not represented though is taken into consideration by the AERMOD model

The stack positions, height and diameters of the considered buildings are shown in table 1. Stack heights are particularly important as the mainly determine the plume rise height, a factor which strongly affects the dispersion behaviour.

Terrain and meteorological information also play an important role in the dispersion of pollutants in the air thus suitable information have been collected and used. In particular a set of available meteorological data corresponding to the selected location have been collected and include, among the others, data concerning the precipitations, the atmospheric stability classes and winds (both intensity and direction distributions as depicted in Figures 3a and 3b respectively). On the other hand terrain information in-

cludes all the information concerning the elevations of the area.

		X	Y
Coke Ovens	Underfiring	1950	1050
	Coke Quenching	1800	850
	Coke-Side Arrestment	2000	950
Sinter Plant	Main Stack	1700	1550
	Dedust Stack	1650	1400
Blast Furnaces	Stoves	2350	1550
	Casthouse Ventilation	2350	1500
BOF	Primary Extraction	2950	1800
	Secondary Ventilation	2850	1700
Hot Mill	Reheating Furnaces	1800	2350
Power Plant	Boilers	2100	1900

**Table 4.** Position of the buildings within the plant

The data on the emissions of the main stacks of the plant have been extrapolated from the BREF and take into account several aspects of the pollutants mentioned in part 1:

- For each stack gas temperature, exit velocity and emission duration
- For each pollutant emitted by each stack concentrations and mass emission rates

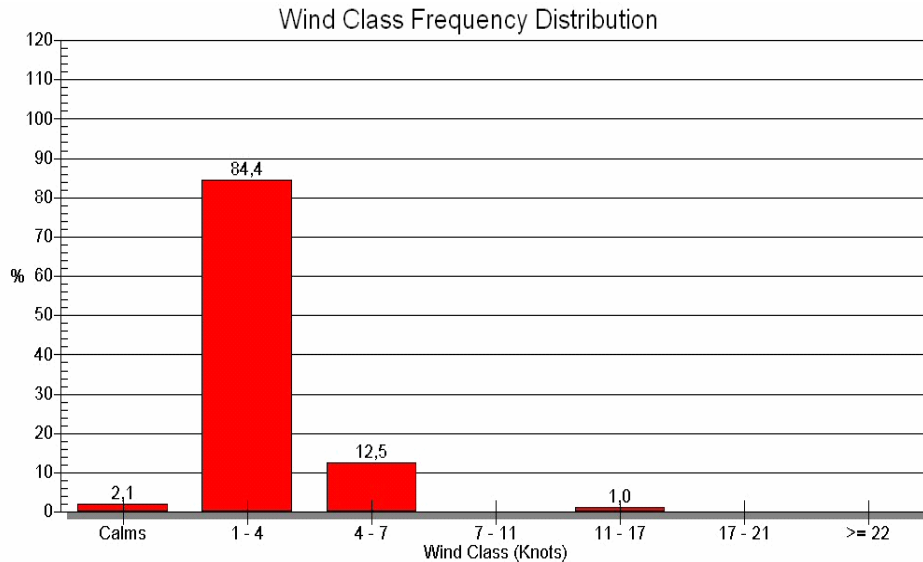

**Figure 3a.** Wind class frequency distribution for the case base

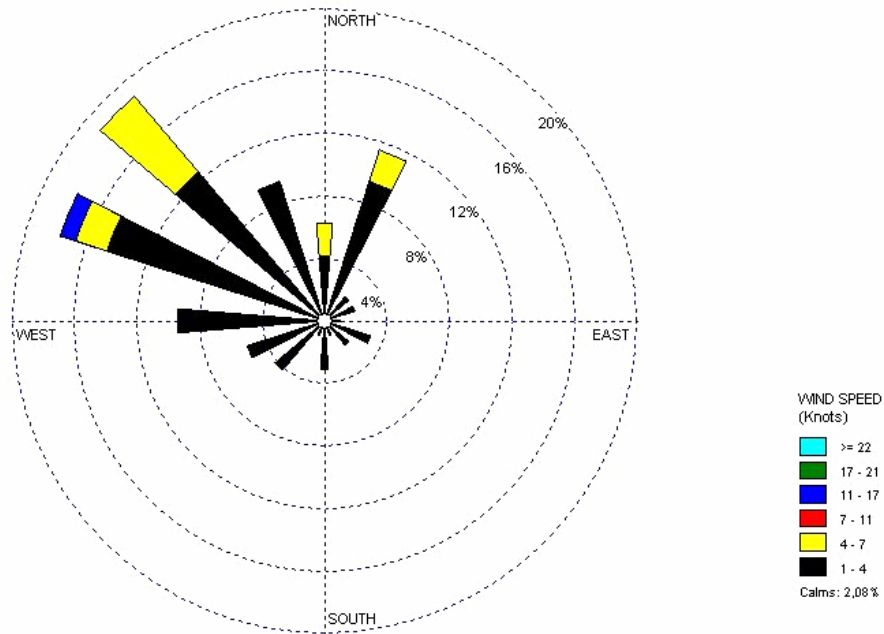

Figure 3b. Wind rose for the considered case base meteorological data

### Part 3. The results of the simulation

The data mentioned in section 2 for the case base definition have been used for the simulation of the selected pollutants in the atmosphere by using the AERMOD dispersion model, described in section 2.

In this case AERMOD has been used for the calculation of the ground concentration for all the considered pollutants though it also allows the calculation of other quantities such as for instance the maximum concentration over a period at different height by respect to the ground level. Moreover it would be possible to calculate the influence of the emission produced by each single stack on the atmospheric concentration of specific pollutants though in this work only the global effect was considered.

For its computation AERMOD needs that the user specifies a set of *receptors* which correspond to the coordinates (including the elevation) where the software will calculate the pollutants concentrations. Within this work it was decided to place receptors evenly over an external area near the plant. The considered area is a circle centered in the center of the plant and with a diameter of 12 km.

Before the AERMOD simulation takes place it is necessary to use AERMET, the meteorological preprocessor coupled with AERMOD, which preprocesses the terrain and meteorological data in order to create some metadata suitable for the subsequent use in the main processing phase.

Simulations were carried out for all pollutants. Each simulation is performed by the calculator in 10-20 seconds. The results are provided by AERMOD in a wide table reporting for each receptor the specific pollutant concentration. For each receptor average pollutant concentration and maximum concentration (stating the time period where such concentration was obtained) are automatically calculated. Due to the space constraints it is impossible to present all the obtained results in a detailed manner, thus they are reported by means of the pictures of Figure 4a-h which describe the average concentrations in the considered areas in micrograms/m<sup>3</sup>.

The results provided by the model reflect SP9.3 expectations and are in accordance with input data. Moreover the results show that the concentrations of main pollutants in the area nearby the plant are below the limits established by current legislation.

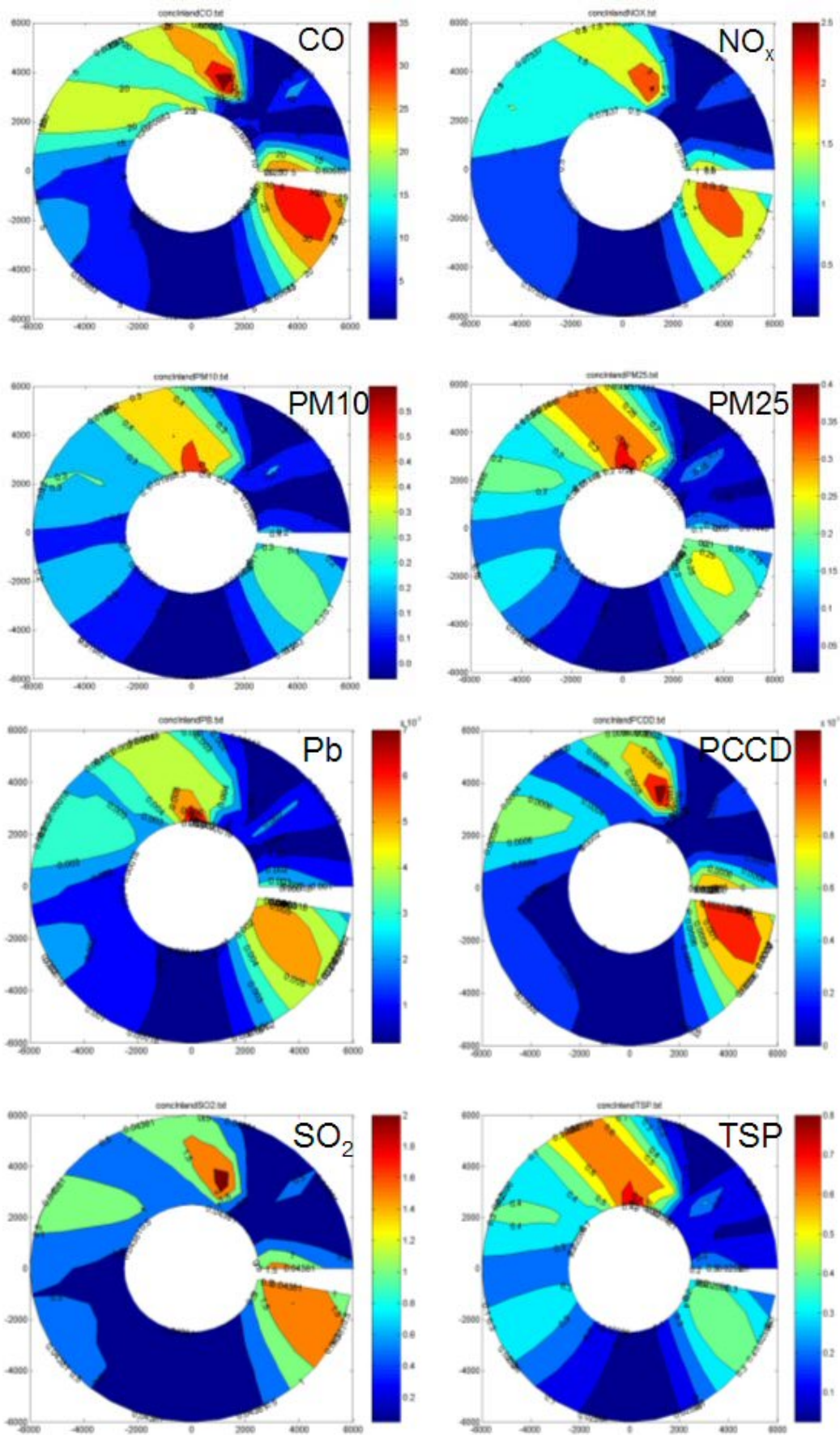

**Figure 4a-h.** The pictures show the results of the AERMOD simulation of air dispersion for the following pollutants (from left top to right bottom): CO, NO<sub>x</sub>, PM<sub>10</sub>, PM<sub>25</sub>, Pb, PCCD, SO<sub>2</sub>, TSP.

## Conclusion

In this paper it was presented part of the work carried out by SP9.3 during the ULCOS project in the framework of the assessment of the local impact of a steel plant. In particular it was assessed the effect of the main pollutants ( $\text{NO}_x$ ,  $\text{SO}_2$ , TSP,  $\text{PM}_{10}$ ,  $\text{PM}_{25}$ , CO, Pb, PCDD) produced by the steel plant by means of the simulation of their dispersion in the atmosphere. The simulation was done exploiting a common air dispersion model which, on the basis of the plant configuration, the emission characteristics, local meteorologic and terrain data calculates the average ground concentration of the examined pollutants.

The steel plant used for the assessment of the local impact is a standard 4Mt/y HRC BF steel plant (case base) for which main emission data were extrapolated from the BREF. Meteorological and terrain data correspond to the real measures taken for the hypothetical location of this average plant in central Europe.

The adopted model for the simulation is AERMOD, a common model whose reliability is proven and which, together with its meteorological preprocessor (AER-MET) is suitable for this study.

The results provided by the model show that the concentrations of main pollutants in the area nearby the plant are below the limits established by current legislation.

In the future these results will be used for comparisons of the case base with new technologies and for further considerations. Moreover other figures characterizing the environmental impact of air pollutants can be calculated by means of the AERMOD model.

## Acknowledgements

The present work is part of the ULCOS program, which operates with direct financing from its 48 partners, especially of its core members (Arcelor-Mittal, Corus, TKS, Riva, Voestalpine, LKAB, Saarstahl, Dillinger Hütte, SSAB, Ruukki and Statoil), and has received grants from the European Commission under the 6<sup>th</sup> Framework RTD program and the RFCS program<sup>1</sup>.

## References

- [1] Sutton, O.G., "The problem of diffusion in the lower atmosphere", *QJRMS*, 73:257, 1947 and "The theoretical distribution of airborne pollution from factory chimneys", *QJRMS*, 73:426, 1947
- [2] Beychok, Milton R. (2005). *Fundamentals Of Stack Gas Dispersion*, 4th Edition, author-published. ISBN 0-9644588-0-2. [www.air-dispersion.com](http://www.air-dispersion.com)

- [3] Turner, D.B. (1994). *Workbook of atmospheric dispersion estimates: an introduction to dispersion modeling*, 2nd Edition, CRC Press.

- [4] Briggs, G.A., "Some recent analyses of plume rise observation", *Proc. Second Internat'l. Clean Air Congress*, Academic Press, New York, 1971

- [5] Briggs, G.A., "Discussion: chimney plumes in neutral and stable surroundings", *Atmos. Envir.*, 6:507-510, 1972

- [6] Prater, E.T. and Midgley, C., "A new air dispersion modeling system is helping create more accurate industrial source models", *Environmental Protection*, Vol. 17, No. 3, Stevens Publishing

- [7] "AERMOD: Latest Features and Evaluation Results" EPA report (EPA-454/R-03-003)

- [8] Cimorelli Alan J., Perry Steven G., Venkatram Akula, Weil Jeffrey C., Paine Robert J., Wilson Robert B., Lee Russell F., Peters Warren D., Brode Roger W., "AERMOD: A dispersion model for industrial source applications. Part I. General model formulation and boundary layer characterization", *Journal of applied meteorology*, 2005, vol. 44, n°5, pp. 682-693

- [9] Eric Hendricks, D. A. Burrows, S. Diehl, and R. Keith, "Dispersion in the downtown Oklahoma City domain: comparisons between the Joint Urban 2003 data and the RUSTIC/MESO models", 13th Conference on the Applications of Air Pollution Meteorology with the Air and Waste Management Assoc Fifth Conference on Urban Environment

- [10] A. Sato, Y. Ichikawa, "A Gis-based dispersion model for predicting pollution from cogeneration systems in urban areas", 10<sup>th</sup> HARMO Conferences Harmonisation within Atmospheric Dispersion Modelling for Regulatory Purposes, 2005 Crete

- [11] Steven R. Hanna, Bruce A. Egan, John Purdum, Jen Wagler, "Evaluation of the ADMS, AERMOD, and ISC3 dispersion models with the OPTEX, Duke Forest, Kincaid, Indianapolis and Lovett field datasets", *International Journal of Environment and Pollution* 2001 - Vol. 16, No.1/2/3/4/5/6 pp. 301-314

- [12] John I. Walker, Mark Scaplen, Fiji George, "ISCST3, AERMOD and CALPUFF: a comparative analysis in the environmental assessment of a sour gas plant", *Environmental Progress*, Volume 25 Issue 1, Pages 12 – 17, May 2006

---

<sup>1</sup> Priority 3 of the 6<sup>th</sup> Framework Programme in the area of "Very low CO<sub>2</sub> Steel Processes", in co-ordination with the 2003 and 2004 calls of the Research Fund for Coal and Steel